



Design Update Bulletin

Combustion Systems

November 2002

No. 112.1

New pivot pin design saves hundred of man-hours when replacing tilting coal nozzle tips on tangential coal fired units...

“Coal Nozzle Tip Pivot Pins ”



A new FWEC pivot pin design for tilting coal nozzle tips eliminates the need to remove stationary coal nozzle assemblies each time coal nozzle tips and/or seal plates need replaced...

- Demonstrated savings of 70 to 100 man- hours per coal nozzle tip when compared to removing stationary coal nozzles.
- Allows quick replacement of coal nozzle tips from the furnace during short outages.
- Eliminates need to re-align coal piping following each replacement.
- Applicable to all tilting coal nozzle tips.
- Standard on all FWEC tangential “Double Shroud” coal nozzle tips.
- Demonstrated long term tilt reliability

Replacing tilting coal nozzle tips on tangential fired units is a labor intensive, time consuming and costly procedure. The normal process involves disconnecting the fuel piping, removing the windbox panel and linkage, followed by removing the stationary coal nozzle assembly. Once the coal nozzle assembly is removed, the old nozzle tip and seal plate is replaced with new components. The procedure is then repeated with the added complication of aligning the entire nozzle assembly to prevent tilt problems. Time studies of the process indicate 70 to 100 man-hours are typically required to change-out coal nozzle tips. This equates to between \$4,000 and \$7000 dollars per coal nozzle tip, not including the lost generation due to extended outage time. With experience, using FWEC coal nozzle tip pivot pins can reduce the process to less than 10 man-hours.

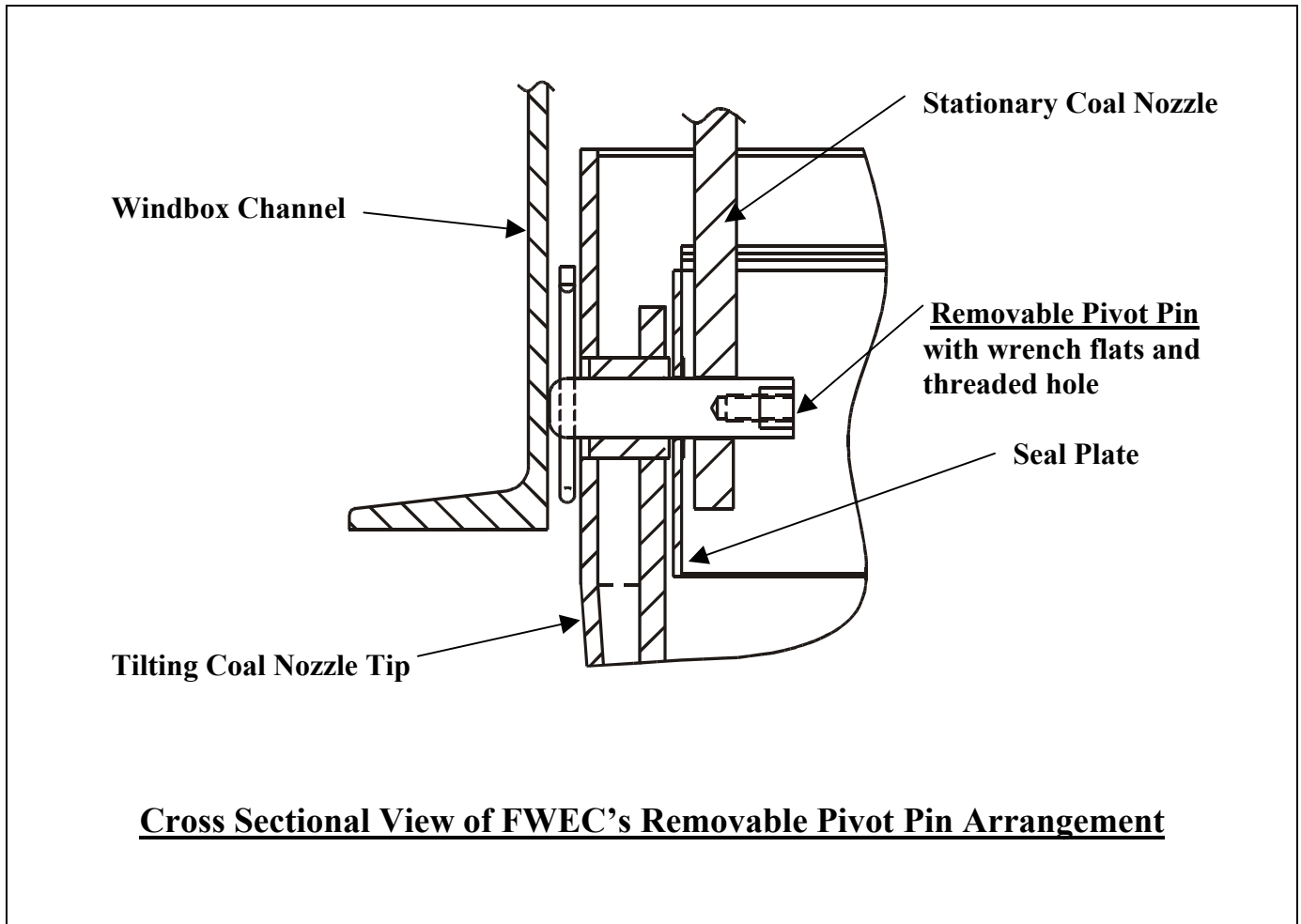

The information presented above is continually updated. Please contact your local Foster Wheeler Power Group office for specific details.

Foster Wheeler Power Group – U.S./International Service Centers

Hdqtrs. Clinton, New Jersey
Perryville Corporate Park
Clinton, NJ 08809-4000
(908) 713-2260
Fax: (908) 713-2285
parts@fwc.com

Chicago Illinois
1401 Branding Lane Suite 315
Downers Grove, IL 60515
(630) 241-2050
Fax: (630) 241-2050

Atlanta, Georgia
1000 Johnson Ferry Road
Marietta, GA 30068
(770) 509-0337
Fax: (770) 509-0797

International Office
9645 Scranton Road Suite 230
San Diego, CA 92121-1761
(858) 458-3187
Fax: (858) 558-3406